



Bluetooth Measurement Interfaces

The BTC-4149 (for R&D) and BQC-4149 (For QC)

Listen offers 2 Bluetooth interfaces from Portland Tool & Die, the laboratory-grade BTC-4149 and the low cost BQC-4149 for production line use. These are ideal for measuring and characterizing Bluetooth audio devices including handsets, headsets, speakers, car kits and other devices with Bluetooth audio input or output. These interfaces connect your bluetooth device to SoundCheck, offering full control over all Bluetooth protocol settings and explicit control over the CODEC choice and transmitter power. This enables devices to be tested under specific operating conditions, and enables comparison of characteristics such as frequency response using different compression algorithms or sample rates.

The BTC-4149 for R&D

The BTC-4149 measures both Bluetooth sink devices (e.g. headsets, speakers and car kits) and Bluetooth source devices (e.g. phones and dongles), offering a comprehensive range of features for R&D users. These include:

- Bluetooth 3.0 compliant RF interface
- Comprehensive suite of codecs, protocols and other parameters including:
 - A2DP: SBC, aptX, aptX HD and aptX-Low Latency codecs
 - Hands Free Protocol (HFP) and Headset Protocol (HSP): CVSD and mSBC codecs
- Full control over bluetooth protocol settings, codec choice and transmitter power
- Control via touch-screen panel on the front of the instrument, or directly via SoundCheck
- Pairing via inquiry/discovery or directly by device address
- The host interfaces via USB for both audio and control data and a parallel SPDIF interface for audio data. Audio is always transported in the digital domain to maximize measurement fidelity.

The BQC-4149 for QC

The BQC-4149 Bluetooth interface is designed for high volume production line testing of Bluetooth sink devices such as headsets, speakers and car kits. Features include:

- Rugged and compact, measuring just 30x64x136mm
- Simple to setup and use with just one USB connection to the computer for power and control.
- Bluetooth 3.0 compliant RF interface
- Includes codecs required for bluetooth sink testing including:
 - A2DP: SBC codecs
 - Headset Protocol (HSP): CVSD and mSBC codecs
- Control over the codec choice, and transmitter power
- Control via the USB virtual com port using a command line utility, or from within SoundCheck for simple integration with your test sequences.
- Uses the same internal components as the BTC-4149 to guarantee that measurements made with one can be reproduced with the other.
- Low cost



BTC-4149 Research Grade Bluetooth Interface



BQC-4149 Production Line Bluetooth Interface

Please note that the BTC-4149 and the BQC-4149 are updates to the earlier BTC-4148 and BQC-4148 models, and feature an updated bluetooth chip. The new 4149 versions ONLY work with SoundCheck version 17 and later; the older 4148 models work with SoundCheck versions 14 -16. Please contact a sales engineer to discuss compatibility in more detail before purchasing if you are not using the current version of SoundCheck.

Bluetooth Measurement Interfaces (cont.)

Setup Diagram

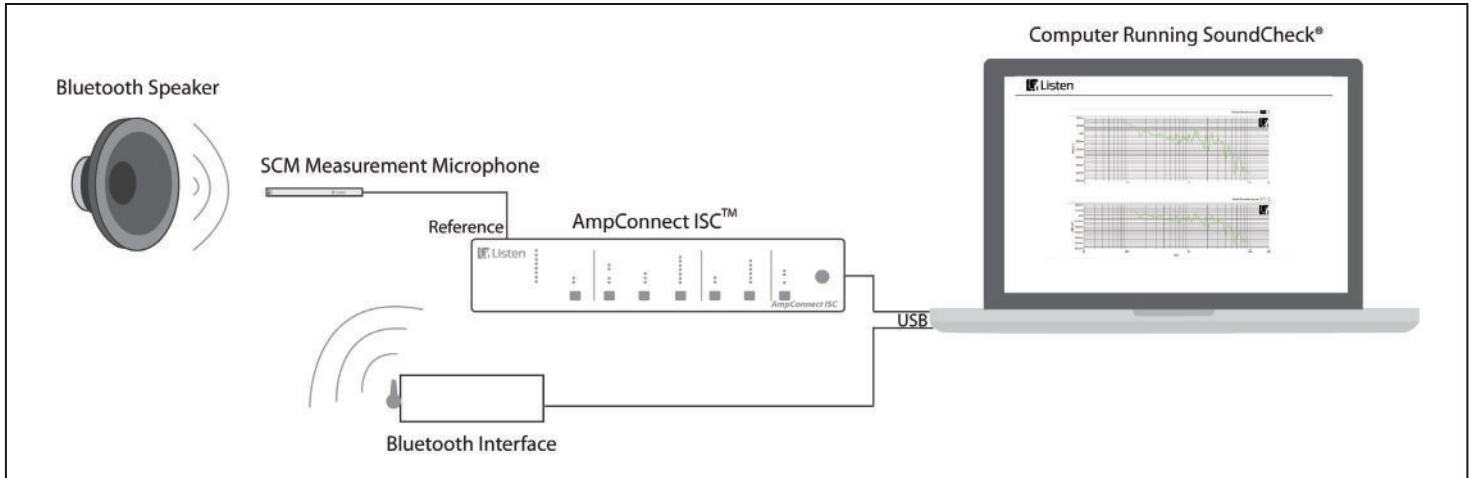

Specifications & Comparison

	BTC-4149	BQC-4149
Test Bluetooth Sink Devices (headsets, speakers and car kits)	✓	✓
Test Bluetooth Source Devices (phones and dongles)	✓	
User Interface	Touchscreen/USB (SoundCheck compatible)	USB (SoundCheck Compatible)
Digital Audio Interface	SPDIF / USB	USB
Bluetooth RF Interface	N-type	SMA
Bluetooth RF	Transmit Power: +4 dBm; Receive Sensitivity: -88 dBm	
Bluetooth Specification	Bluetooth 3.0 compliant	
Bluetooth Profiles	A2DP HFP/HSP	A2DP HSP
Bluetooth Modes	Source, Sink	Source
Codecs		
A2DP	SBC aptX aptX HD aptX - Low Latency	SBC
HFP/HSP	Voice (CVSD), Wide-Band Voice (mSBC)	
Compatibility	Windows and Mac	
Dimensions (H x W x D)	86mm x 271mm x 211mm	30mm x 64mm x 140mm
Weight	1.6 kg	0.18 kg
Power	12VDC, 24W power input. Supplied with universal 100-240 VAC / 50 – 60 Hz power supply	USB Bus

NOTE: Specifications are subject to change. Please contact Listen for current information or questions.